

Top & Bottom Drive Belt Adjustable Carton Sealer

Model:

CT-55LP

Excellent for "low profile" boxes.

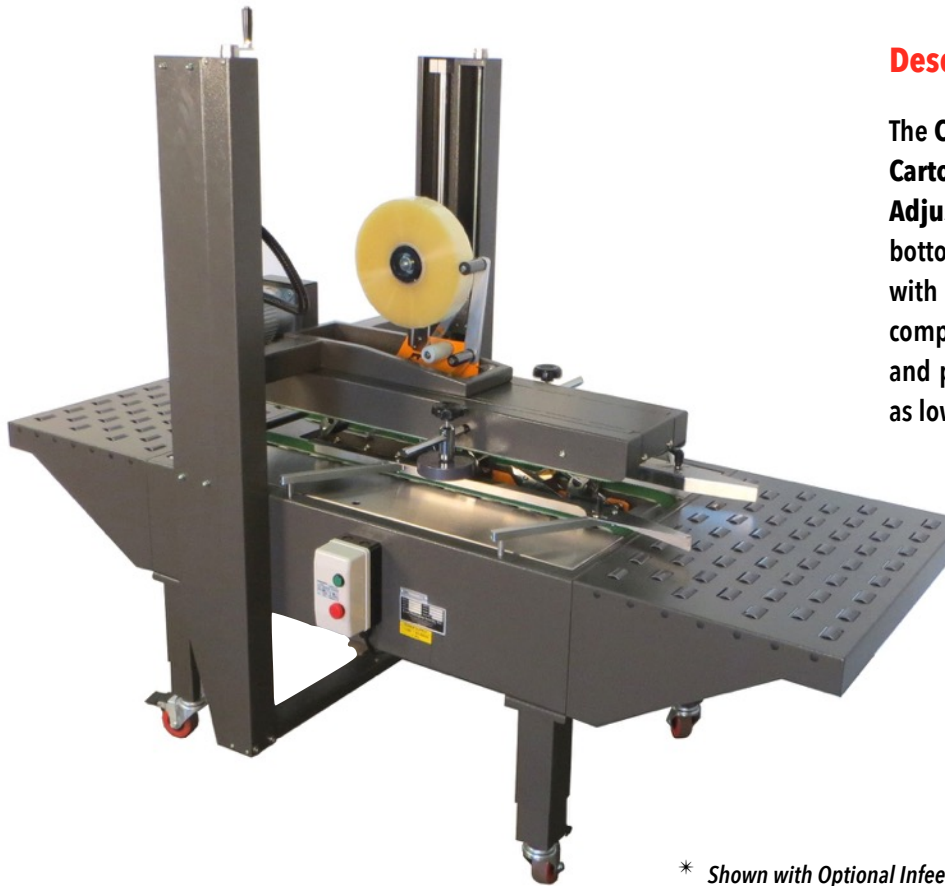

Description

The CT-55LP (Low Profile) Semi-Automatic Uniform Carton Sealer with Easy Manual Carton Size Adjustment has a 4-Belt Design (2 top and 2 bottom) and features our new "Piranha" tape head with "Easy Thread Design." The machine comes complete with adjustable height legs, power cord and plug. Offset tape heads allow unit to tape a box as low as 2" tall.

* Shown with Optional Infeed and Discharge Roller Conveyor & Casters

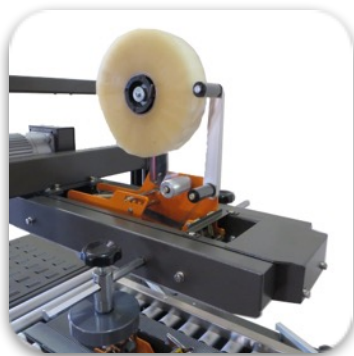

Offset Tape Head Design With Adjustable Box Side Guides.

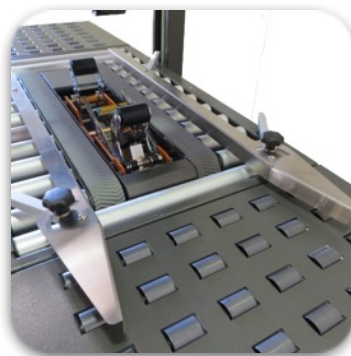

Heavy Duty Top and Bottom 4 Drive Belt System For Positive Grip Pressure.



New "Piranha" Tape Head Features An Easy Thread Design with Optimizer Arm.

CT-55LP (Low Profile) CARTON SEALER

The operator simply folds the top flaps of the corrugated carton and feeds it into the machine. The CT-55LP applies a single tape strip to both the top and bottom of the case simultaneously. This four belt drive design is a heavy duty versatile machine designed for dependable performance and easy operation. The CT-55LP can be easily adjusted in only seconds to process a different size carton. Excellent for low profile boxes.

STANDARD FEATURES:

- "Patented" Tape Head with "Easy Thread" Design
- Interchangeable Tape Heads
- Side Pressure Rollers to Close Box Top
- 2 Top & 2 Bottom Drive Belts -Positive Feed
- Fully Adjustable Legs From 28-32"

OPTIONAL FEATURES:

- 3" (72mm) Tape Heads
- Infeed Conveyor
- Exit Conveyor
- Stainless Steel Frame
- Heavy Duty Locking Casters
- Spare Parts Kit

CARTON SIZE: LENGTH: 6" min. to Infinite
WIDTH: 7" min. to 20" max.
HEIGHT: 2" min. to 20" max.

MACHINE SIZE: 38"L x 33"W x 58"H

MACHINE SPEED: 75ft./min. up to 2000 cartons per hour. Production rate depends on carton size and operator dexterity

ELECTRICAL: 110 Volt, 1 Phase, 10 Amp

WEIGHT: 320 lbs. Shipping Weight: 370 lbs.

MAX BOX WEIGHT: 65lbs.

TAPE HEAD SPECS: 2" (48mm) Wide - 1,000 yard or 1,500 yard rolls.

WARRANTY: 2 year limited warranty on parts

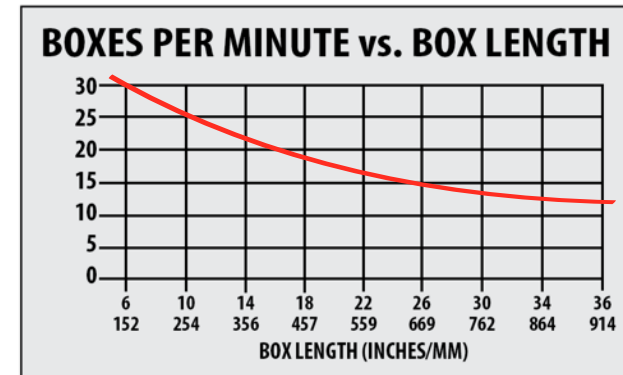
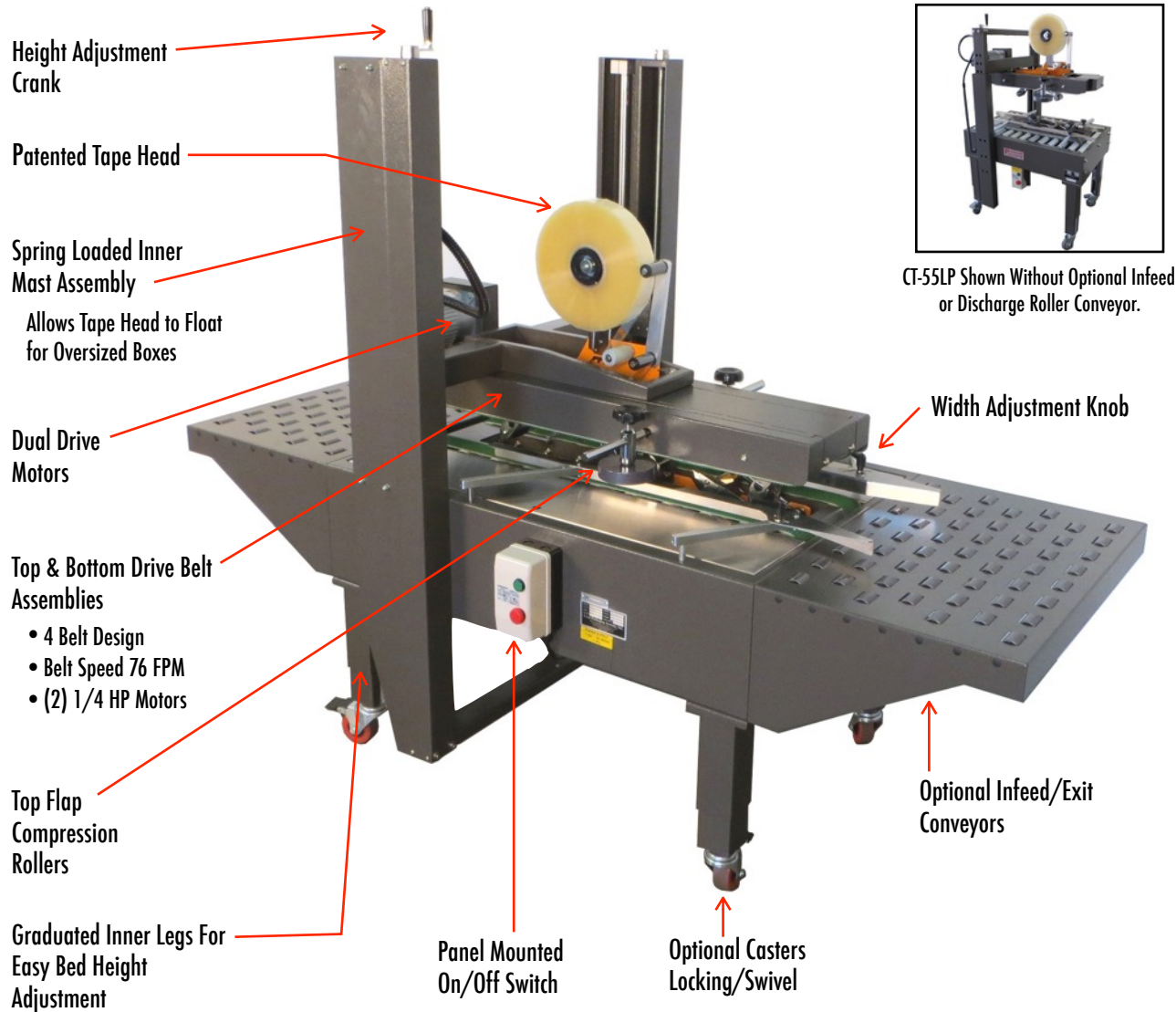
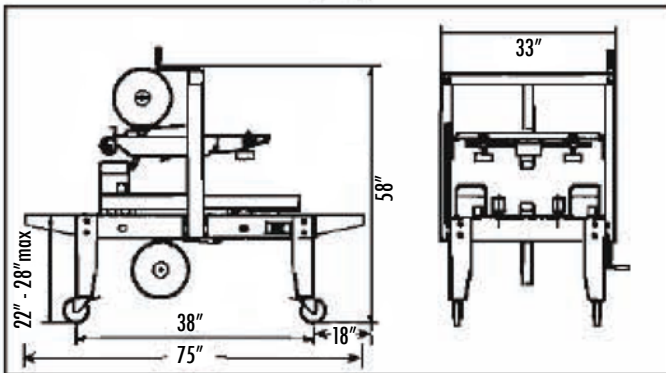

Shown With Optional Ansur U2 Ink Jet System